

ARIA AUD-MON-V • 1RU RACK MOUNT AUDIO MONITORING WITH LCD METERING



Cobalt Digital Inc. introduces the **ARIA AUD-MON-V**, a 1RU AUDIO MONITORING PANEL featuring best-in-class sound monitoring from a compact rack mount size device. Developed as a result of customer feedback, the sound is produced by an efficient Class-D amplifier with DSP and specially selected speaker components. The **ARIA AUD-MON-V** front panel is simplified and has no deep menus to drill down thru. Each of the 8 individual front panel volume controls to the left of the display has a push to mute / solo feature. The V shape knobs are ergonomically positioned to quickly locate and adjust channels of interest. A push to mute master speaker volume control is placed to the right of the LCD display. The LCD display can present audio levels and live video. The display can be expanded in several ways to view additional audio channels. A 1/4 inch headphone jack is placed to the left of the controls to mute the speakers when headphones are plugged in. Factory presets provide a solid starting point out of the box from which to customize your favorite set-ups.

The color LCD display keeps you informed of 16 channels of SDI metering, 64 channels of MADI, or up to 64 *DANTE channels and their status. The display will show PPM with peak hold and Loudness. From the browser UI, you can arrange the screen to display different combinations of input channels and save those layout settings to the preset buttons located on the front panel.

The audio monitor features an Ethernet port for IP-based UI configuration. The web-based browser control system includes input and channel assignments, button presets, button and panel locks, and other important system management operations. The control system allows different panel setups to be stored and recalled from the browser to provide extremely flexible operations.

After setting up the configuration just as you need it, save and upload that configuration to other **ARIA** audio monitor panels on your network.

ARIA
AUD-MON-V 1RU Audio Monitor

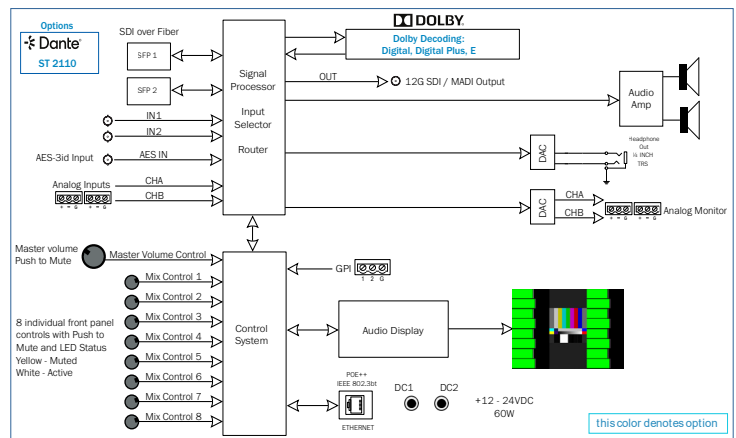

FEATURES

| | |
|--|--|
| LCD display with signal bar graph meters, phase meters, loudness (BS.1770 / R128, LKFS, A/85) status display and live video (scaled) | 2-way, stereo speaker design for intelligibility |
| Inputs (2) 12G SDI / MADI - Automatic frame rate detection and selection of video and embedded audio standards (1) AES (1) GPI (2) Analog | Power (2) External DC power supply connections provide for redundant operation (1) PS-65W-24V-S760KZ is included (1) PoE++ |
| Outputs (1) 12G / MADI (2) Analog | 100/1000 Ethernet with auto-MDIX for remote browser UI configuration and control |
| Individual mute / solo buttons for all 8 volume controls. Master volume and mute control. Programmable shortcut buttons and Lock button function | Downmix from multi-channel sources to L/R stereo or mono mix |
| Simultaneous monitoring of different types of input audio sources | Five-year warranty |

ARIA AUD-MON-V • 1RU RACK MOUNT AUDIO MONITORING WITH LCD METERING

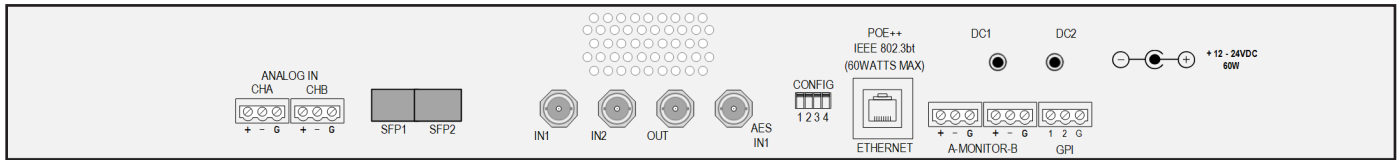

SPECIFICATIONS

| | |
|---|---|
| 30 WATT Class D amplifier (15 watts per side) | Stereo / Left and Right high performance 2-way speaker system |
| Full-sized 75Ω BNC SDI Input 12G/6G/3G/HD/SD and MADI capable | 1/4" TRS headphone jack (mutes speakers when used) |
| Full-sized 75Ω BNC AES3id PCM Input Sample rates: 32, 44.1, 48, 96 kHz | (2) SFP cages allow connector and signal processing options: SDI over Fiber (up to 12G SDI) DANTE (1G) ST 2110 (10/25G) |
| Acoustic Frequency Response: 150 Hz to 16 kHz +/- dB | (2) Dual (redundant) External DC power supply inputs (1) 65 watt 24v DC supply is included (1) PoE++ with automatic changeover to/from DC supply included |
| Hum and Noise: Better than -60dB below full output | Maximum SPL 93dBA before protection limiting @ 1m |
| Operating Temperature: 0° to 40°C (32° to 104°F) non-condensing | 19 inch wide rack mount metal chassis 1.75 inches tall - 1RU 4 inches deep Weight: 4 lbs |

ORDERING INFORMATION - INCLUDING OPTIONS*

| | |
|---|---|
| ARIA AUD-MON-V 1RU rack mount stereo audio monitor with LCD display bar-graph meters, Phase meters, Loudness, Status, and Live video. | *Power Supply PS-65W-24V-S760KZ Additional external DC power supply for redundancy |
| *SFP -SFP-OE-MSA-3G: 3G/HD/SD-SDI UHD Single Video Optical Receiver (OE) -SFP-OE-MSA-12G: 12G/6G/3G/HD/SD-SDI UHD Single Video Optical Receiver (OE) | Dante® +AUD-MON-DANTE-16: Adds high quality audio monitoring up to 16 DANTE channels. Option is field upgradeable. +AUD-MON-DANTE-64: Adds high quality audio monitoring up to 64 DANTE channels. Option is field upgradeable. |
| *ST 2110 +AUD-MON-2110: Adds SMPTE ST 2110 capability (-20, -30, and 2022-7) for video and audio monitoring. | DOLBY® +AUD-MON-DOLBY-DEC: Provides Dolby Digital, Digital Plus, and E decode functionality. |