

# ROYAL 9917-DA-1x8/2x4-12G

COBALT<sup>®</sup>

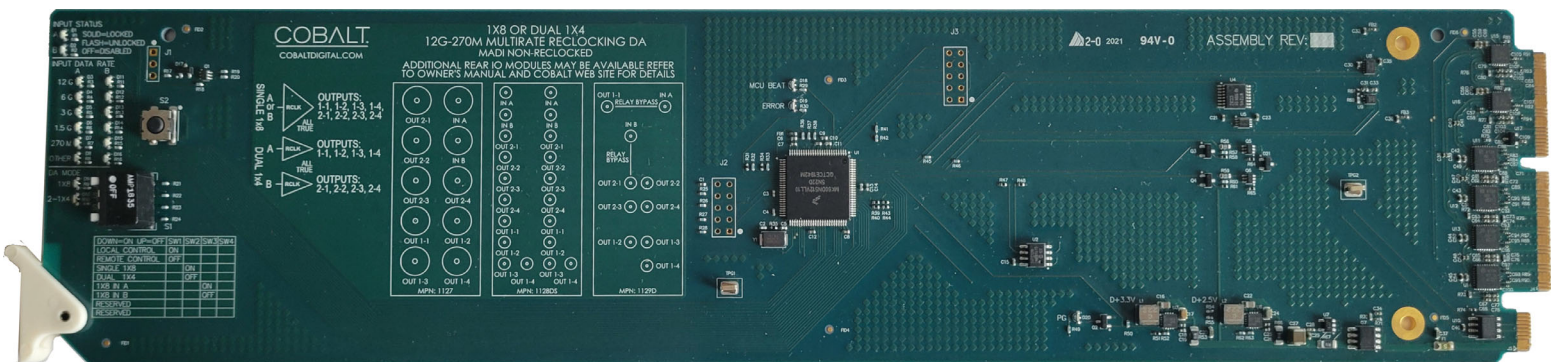

## 1x8/2x4 Dual-Channel 12G/6G/3G/HD/SD/ASI/MADI Reclocking Distribution Amplifier

# Product Manual

COBALT<sup>®</sup>

**Cobalt Digital Inc.**

2506 Galen Drive  
Champaign, IL 61821  
Voice 217.344.1243 • Fax 217.344.1245  
www.cobaltdigital.com

---

## Copyright

©Copyright 2024, Cobalt Digital Inc. All Rights Reserved.

Duplication or distribution of this manual and any information contained within is strictly prohibited without the express written permission of Cobalt Digital Inc. This manual and any information contained within, may not be reproduced, distributed, or transmitted in any form, or by any means, for any purpose, without the express written permission of Cobalt Digital Inc. Reproduction or reverse engineering of software used in this device is prohibited.

## Disclaimer

The information in this document has been carefully examined and is believed to be entirely reliable. However, no responsibility is assumed for inaccuracies. Furthermore, Cobalt Digital Inc. reserves the right to make changes to any products herein to improve readability, function, or design. Cobalt Digital Inc. does not assume any liability arising out of the application or use of any product or circuit described herein.

## Trademark Information

**Cobalt**<sup>®</sup> is a registered trademark of Cobalt Digital Inc.

**Compass**<sup>®</sup> is a registered trademark of Cobalt Digital Inc.

**openGear**<sup>®</sup> is a registered trademark of Ross Video Limited. **DashBoard**<sup>™</sup> is a trademark of Ross Video Limited.

Congratulations on choosing the Cobalt<sup>®</sup> 1x8/2x4 Dual-Channel 12G/6G/3G/HD/SD/ASI/MADI Reclocking Distribution Amplifier. The ROYAL-OG-DA-1x8/2x4-12G card is part of a full line of modular processing and conversion gear for broadcast TV environments. The Cobalt Digital Inc. line includes video decoders and encoders, audio embedders and de-embedders, distribution amplifiers, format converters, remote control systems and much more. Should you have questions pertaining to the installation or operation of your card, please contact us at the contact information on the front cover.

<b>Manual No.:</b>	ROYAL-9917-DA-1x8/2x4-12G-OM
<b>Document Version:</b>	V1.0
<b>Release Date:</b>	December 13, 2024
<b>Applicable for Firmware Version (or greater):</b>	1.0
<b>Description of product/manual changes:</b>	First release

# Table of Contents

---

<b>Chapter 1</b>	<b>Introduction . . . . .</b>	<b>1-1</b>
	Overview .....	1-1
	Manual Conventions.....	1-1
	Warnings, Cautions, and Notes .....	1-2
	Labeling Symbol Definitions.....	1-3
	Safety Summary .....	1-3
	Warnings.....	1-3
	Cautions .....	1-3
	Royal 9917-DA-1x8/2x4-12G Functional Description .....	1-4
	Royal 9917-DA-1x8/2x4-12G Rear I/O Modules .....	1-5
	Technical Specifications.....	1-6
	Warranty and Service Information .....	1-7
	Cobalt Digital Inc. Limited Warranty.....	1-7
	Contact Cobalt Digital Inc.....	1-8
<b>Chapter 2</b>	<b>Installation and Setup . . . . .</b>	<b>2-1</b>
	Overview .....	2-1
	Card Control and Status.....	2-1
	Card Status Indicators and Switches .....	2-3
	Installing the Royal 9917-DA-1x8/2x4-12G Into a Frame Slot.....	2-5
	Installing a Rear I/O Module .....	2-6
	Royal 9917-DA-1x8/2x4-12G Rear I/O Modules .....	2-8
<b>Chapter 3</b>	<b>Operating Instructions. . . . .</b>	<b>3-1</b>
	Overview .....	3-1
	Accessing the Royal 9917-DA-1x8/2x4-12G Card via Remote Control .....	3-1
	Accessing the Royal 9917-DA-1x8/2x4-12G Card Using DashBoard™ ..	3-1
	Checking Royal 9917-DA-1x8/2x4-12G Card Information and Status .....	3-1
	Royal 9917-DA-1x8/2x4-12G Function Menu List and Descriptions .....	3-2
	Device Controls .....	3-3
	Alarm Controls .....	3-3
	Troubleshooting.....	3-4
	Basic Troubleshooting Checks .....	3-5
	Royal 9917-DA-1x8/2x4-12G Processing Error Troubleshooting.....	3-6
	Troubleshooting Network/Remote Control Errors .....	3-6
	In Case of Problems.....	3-6

---

---

---

---

# Introduction

## Overview

This manual provides installation and operating instructions for the **Royal 9917-DA-12G-1x8/2x4 Dual-Channel 12G/6G/3G/HD/SD Reclocking Distribution Amplifier** (also collectively referred to herein as the Royal 9917-DA-1x8/2x4-12G).

**This manual** consists of the following chapters:

- **Chapter 1, “Introduction”** – Provides information about this manual and what is covered. Also provides general information regarding the Royal 9917-DA-1x8/2x4-12G.
- **Chapter 2, “Installation and Setup”** – Provides instructions for installing the Royal 9917-DA-1x8/2x4-12G in a frame, and optionally installing a Royal 9917-DA-1x8/2x4-12G Rear I/O Module.
- **Chapter 3, “Operating Instructions”** – Provides overviews of operating controls and instructions for using the Royal 9917-DA-1x8/2x4-12G.

**This chapter** contains the following information:

- **Manual Conventions (p. 1-1)**
- **Safety Summary (p. 1-3)**
- **Royal 9917-DA-1x8/2x4-12G Functional Description (p. 1-4)**
- **Technical Specifications (p. 1-6)**
- **Warranty and Service Information (p. 1-7)**
- **Contact Cobalt Digital Inc. (p. 1-8)**

## Manual Conventions

In this manual, display messages and connectors are shown using the exact name shown on the Royal 9917-DA-1x8/2x4-12G itself (for example, connector names are shown like this: **SDI IN A**)

In this manual, the terms below are applicable as follows:

- **Frame** refers to the HPF-9000, HPF-9500, HPF-MAX, oGx, OG3-FR, 8321, or similar 20-slot frame that houses Cobalt® or other cards.

- **Device** and/or **Card** refers to a Cobalt® or other card.
- **System** and/or **Video System** refers to the mix of interconnected production and terminal equipment in which the Royal 9917-DA-1x8/2x4-12G and other cards operate.

## Warnings, Cautions, and Notes

Certain items in this manual are highlighted by special messages. The definitions are provided below.

### Warnings

Warning messages indicate a possible hazard which, if not avoided, could result in personal injury or death.



### Cautions

Caution messages indicate a problem or incorrect practice which, if not avoided, could result in improper operation or damage to the product.

### Notes

Notes provide supplemental information to the accompanying text. Notes typically precede the text to which they apply.

Labeling Symbol Definitions

	<p>Important note regarding product usage. Failure to observe may result in unexpected or incorrect operation.</p>
	<p>Electronic device or assembly is susceptible to damage from an ESD event. Handle only using appropriate ESD prevention practices.</p> <p>If ESD wrist strap is not available, handle card only by edges and avoid contact with any connectors or components.</p>
	<p>Symbol (WEEE 2002/96/EC)</p> <p>For product disposal, ensure the following:</p> <ul style="list-style-type: none"> <li>• Do not dispose of this product as unsorted municipal waste.</li> <li>• Collect this product separately.</li> <li>• Use collection and return systems available to you.</li> </ul>

Safety Summary

Warnings

**! WARNING !**

To reduce risk of electric shock do not remove line voltage service barrier cover on frame equipment containing an AC power supply. **NO USER SERVICEABLE PARTS INSIDE. REFER SERVICING TO QUALIFIED SERVICE PERSONNEL.**

Cautions

**CAUTION**

This device is intended for environmentally controlled use only in appropriate video terminal equipment operating environments.

**CAUTION**

This product is intended to be a component product of an openGear® or equivalent frame. Refer to the frame Product Manual for important safety instructions regarding the proper installation and safe operation of the frame as well as its component products.

**CAUTION**

If required, make certain Rear I/O Module(s) is installed before installing the Royal 9917-DA-1x8/2x4-12G into the frame slot. Damage to card and/or Rear I/O Module can occur if module installation is attempted with card already installed in slot.

**CAUTION**

If card resists fully engaging in rear I/O module mating connector, check for alignment and proper insertion in slot tracks. Damage to card and/or rear I/O module may occur if improper card insertion is attempted.

---

## Royal 9917-DA-1x8/2x4-12G Functional Description

Figure 1-1 shows a functional block diagram of the Royal 9917-DA-1x8/2x4-12G. With the appropriate rear module, the Royal 9917-DA-1x8/2x4-12G can provide up to 8 DA video outputs.

### Input/Output Formats

The **Royal 9917-DA-1x8/2x4-12G** provides the following inputs and outputs:

- **Inputs:**
  - **12G/6G/3G/HD/SD-SDI IN (A and B)** – two coaxial 12G/6G/3G/HD/SD-SDI/ASI/MADI video inputs
- **Outputs:**
  - **12G/6G/3G/HD/SD-SDI IN (1-8)** – up to 8 coaxial 3G/HD/SD-SDI/ASI/MADI video outputs. All outputs are non-inverting and can be used as SDI or ASI outputs.

### Remote/Local Control

The Royal 9917-DA-1x8/2x4-12G is equipped with card-edge switches that allow the user to change the device mode using Local Control. When Local Control is enabled, DashBoard™ remote control is disabled (and vice-versa).

### Individual Input/Output Controls

Each of the Royal 9917-DA-1x8/2x4-12G inputs and outputs can be enabled and disabled using the Device Mode controls available in the DasBboard™ .



**Royal 9917-DA-1x8/2x4-12G Rear I/O Modules**

The Royal 9917-DA-1x8/2x4-12G physically interfaces to system video connections at the rear of its frame using a Rear I/O Module. The full assortment of Royal 9917-DA-1x8/2x4-12G Rear I/O Modules is shown and described in Royal 9917-DA-1x8/2x4-12G Rear I/O Modules (p. 2-8) in Chapter 2, “Installation and Setup”.

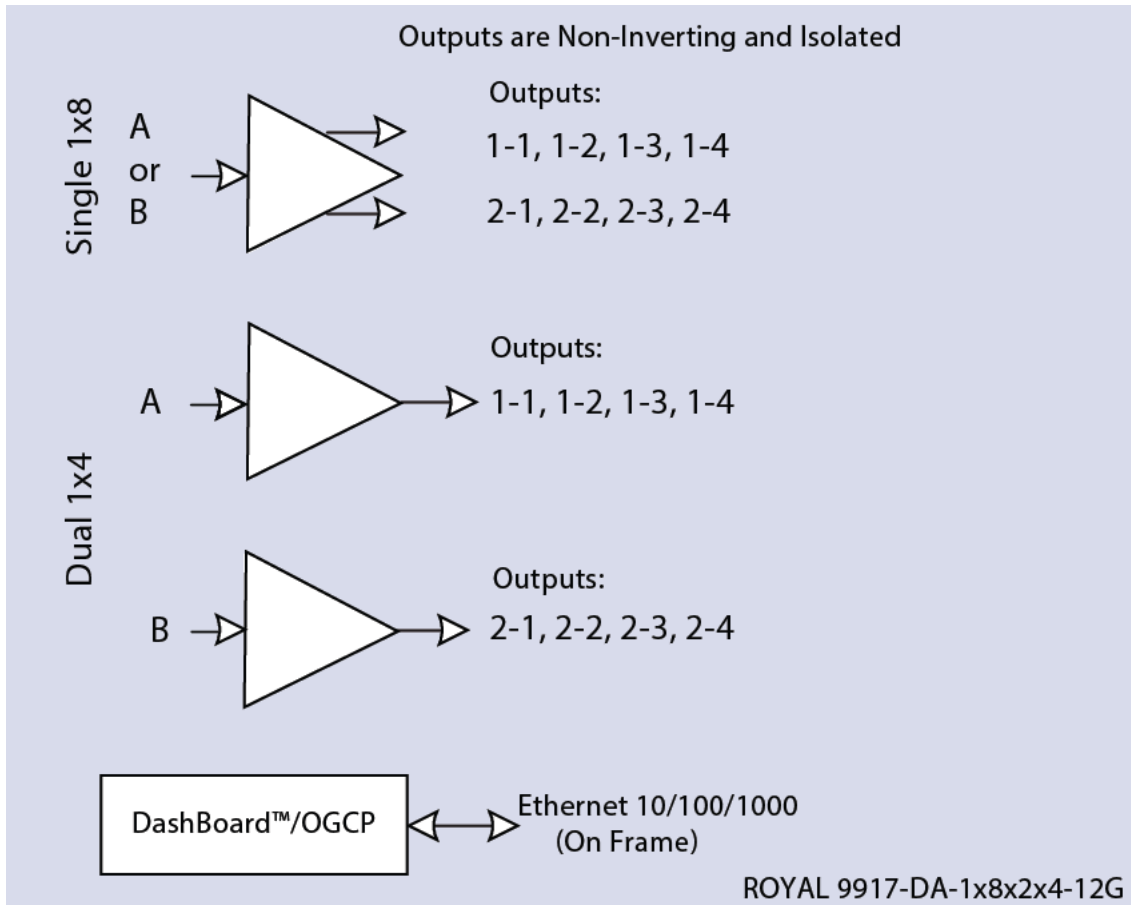

**Figure 1-1 Royal 9917-DA-1x8/2x4-12G Functional Block Diagram**

## Technical Specifications

Table 1-1 lists the technical specifications for the Royal 9917-DA-1x8/2x4-12G cards.

**Table 1-1 Technical Specifications**

Item	Characteristic
Part number, nomenclature	<b>Royal 9917-DA-1x8/2x4-12G</b> 12G/6G/3G/HD/SD Dual-Channel Reclocking Distribution Amplifier, 2 X 4 or 1 X 8 Configurations, Failover Mode
Installation/usage environment	Intended for installation and usage in frame meeting openGear™ modular system definition.
Power consumption	< 3 Watts maximum
Installation Density	Up to 10 cards per 20-slot frame
Environmental: Operating temperature: Relative humidity (operating or storage):	32° – 104° F (0° – 40° C) < 95%, non-condensing
Frame communication	10/100/1000 Mbps Ethernet
Indicators	Input Status indicators
12G/6G/3G/HD/SD-SDI / ASI Inputs	(2) 75Ω coaxial inputs; max (A and B) SDI Formats Supported: SMPTE 259M, SMPTE 292M, SMPTE 424M, SMPTE ST 2082-1, SMPTE ST 2082-10 SDI Return Loss: >15 dB up to 1.485 GHz; >10 dB up to 2.970 GHz
Receive Performance (Cable Length; Belden 1694A)  Note: Cable length is dependent on the rear I/O module.	<p><b>RM20-9917-A Rear I/O Module</b></p> <ul style="list-style-type: none"> <li>• 12Gbps - 55m</li> <li>• 6Gbps - 70m</li> <li>• 3Gbps - 150m</li> <li>• 1.5Gbps - 170m</li> <li>• 270Mbps - 440m</li> </ul> <p><b>RM20-9917-B/S-HDBNC Rear I/O Module</b></p> <ul style="list-style-type: none"> <li>• 12Gbps - 25m</li> <li>• 6Gbps - 60m</li> <li>• 3Gbps - 120m</li> <li>• 1.5Gbps - 140m</li> <li>• 270Mbps - 250m</li> </ul> <p><b>RM20-9917-B-HDBNC Rear I/O Module</b></p> <ul style="list-style-type: none"> <li>• 12Gbps - 20m</li> <li>• 6Gbps - 40m</li> <li>• 3Gbps - 100m</li> <li>• 1.5Gbps - 100m</li> <li>• 270Mbps - 150m</li> </ul>
12G/6G/3G/HD/SD-SDI / ASI Outputs	(8) 75Ω coaxial outputs Signal Level: 800 mV nominal Return Loss: >15 dB at 5 MHz - 1.485 GHz Jitter (wideband): HD < 0.2 UI

---

## Warranty and Service Information

### Cobalt Digital Inc. Limited Warranty

This product is warranted to be free from defects in material and workmanship for a period of five (5) years from the date of shipment to the original purchaser, except that 4000, 5000, 6000, 8000 series power supplies, and Dolby® modules (where applicable) are warranted to be free from defects in material and workmanship for a period of one (1) year.

Cobalt Digital Inc.'s ("Cobalt") sole obligation under this warranty shall be limited to, at its option, (i) the repair or (ii) replacement of the product, and the determination of whether a defect is covered under this limited warranty shall be made at the sole discretion of Cobalt.

This limited warranty applies only to the original end-purchaser of the product, and is not assignable or transferrable therefrom. This warranty is limited to defects in material and workmanship, and shall not apply to acts of God, accidents, or negligence on behalf of the purchaser, and shall be voided upon the misuse, abuse, alteration, or modification of the product. Only Cobalt authorized factory representatives are authorized to make repairs to the product, and any unauthorized attempt to repair this product shall immediately void the warranty. Please contact Cobalt Technical Support for more information.

To facilitate the resolution of warranty related issues, Cobalt recommends registering the product by completing and returning a product registration form. In the event of a warrantable defect, the purchaser shall notify Cobalt with a description of the problem, and Cobalt shall provide the purchaser with a Return Material Authorization ("RMA"). For return, defective products should be double boxed, and sufficiently protected, in the original packaging, or equivalent, and shipped to the Cobalt Factory Service Center, postage prepaid and insured for the purchase price. The purchaser should include the RMA number, description of the problem encountered, date purchased, name of dealer purchased from, and serial number with the shipment.

**Cobalt Digital Inc. Factory Service Center**

2506 Galen Drive

Champaign, IL 61821 USA

www.cobaltdigital.com

Office: (217) 344-1243

Fax: (217) 344-1245

Email: info@cobaltdigital.com

THIS LIMITED WARRANTY IS EXPRESSLY IN LIEU OF ALL OTHER WARRANTIES EXPRESSED OR IMPLIED, INCLUDING THE WARRANTIES OF MERCHANTABILITY AND FITNESS FOR A PARTICULAR PURPOSE AND OF ALL OTHER OBLIGATIONS OR LIABILITIES ON COBALT'S PART. ANY SOFTWARE PROVIDED WITH, OR FOR USE WITH, THE PRODUCT IS PROVIDED "AS IS." THE BUYER OF THE PRODUCT ACKNOWLEDGES THAT NO OTHER REPRESENTATIONS WERE MADE OR RELIED UPON WITH RESPECT TO THE QUALITY AND FUNCTION OF THE GOODS HEREIN SOLD. COBALT PRODUCTS ARE NOT AUTHORIZED FOR USE IN LIFE SUPPORT APPLICATIONS.

COBALT'S LIABILITY, WHETHER IN CONTRACT, TORT, WARRANTY, OR OTHERWISE, IS LIMITED TO THE REPAIR OR REPLACEMENT, AT ITS OPTION, OF ANY DEFECTIVE PRODUCT, AND SHALL IN NO EVENT INCLUDE SPECIAL, INDIRECT, INCIDENTAL, OR CONSEQUENTIAL DAMAGES (INCLUDING LOST PROFITS), EVEN IF IT HAS BEEN ADVISED OF THE POSSIBILITY OF SUCH DAMAGES.

---

## Contact Cobalt Digital Inc.

Feel free to contact our thorough and professional support representatives for any of the following:

- Name and address of your local dealer
- Product information and pricing
- Technical support
- Upcoming trade show information

<b>Phone:</b>	(217) 344-1243
<b>Fax:</b>	(217) 344-1245
<b>Web:</b>	<a href="http://www.cobaltdigital.com">www.cobaltdigital.com</a>
<b>General Information:</b>	info@cobaltdigital.com
<b>Technical Support:</b>	support@cobaltdigital.com

---

# Installation and Setup

## Overview

This chapter contains the following information:

- Card Control and Status (p. 2-1)
- Installing the Royal 9917-DA-1x8/2x4-12G Into a Frame Slot (p. 2-5)
- Installing a Rear I/O Module (p. 2-6)

## Card Control and Status

### CAUTION



This device contains semiconductor devices which are susceptible to serious damage from Electrostatic Discharge (ESD). ESD damage may not be immediately apparent and can affect the long-term reliability of the device.

Always use proper ESD handling precautions and equipment when working on circuit boards and related equipment.

Figure 2-1 shows and describes the card-edge status indicators that provide status information and switches which can be used to provide limited card control without requiring a remote control connection (local control).

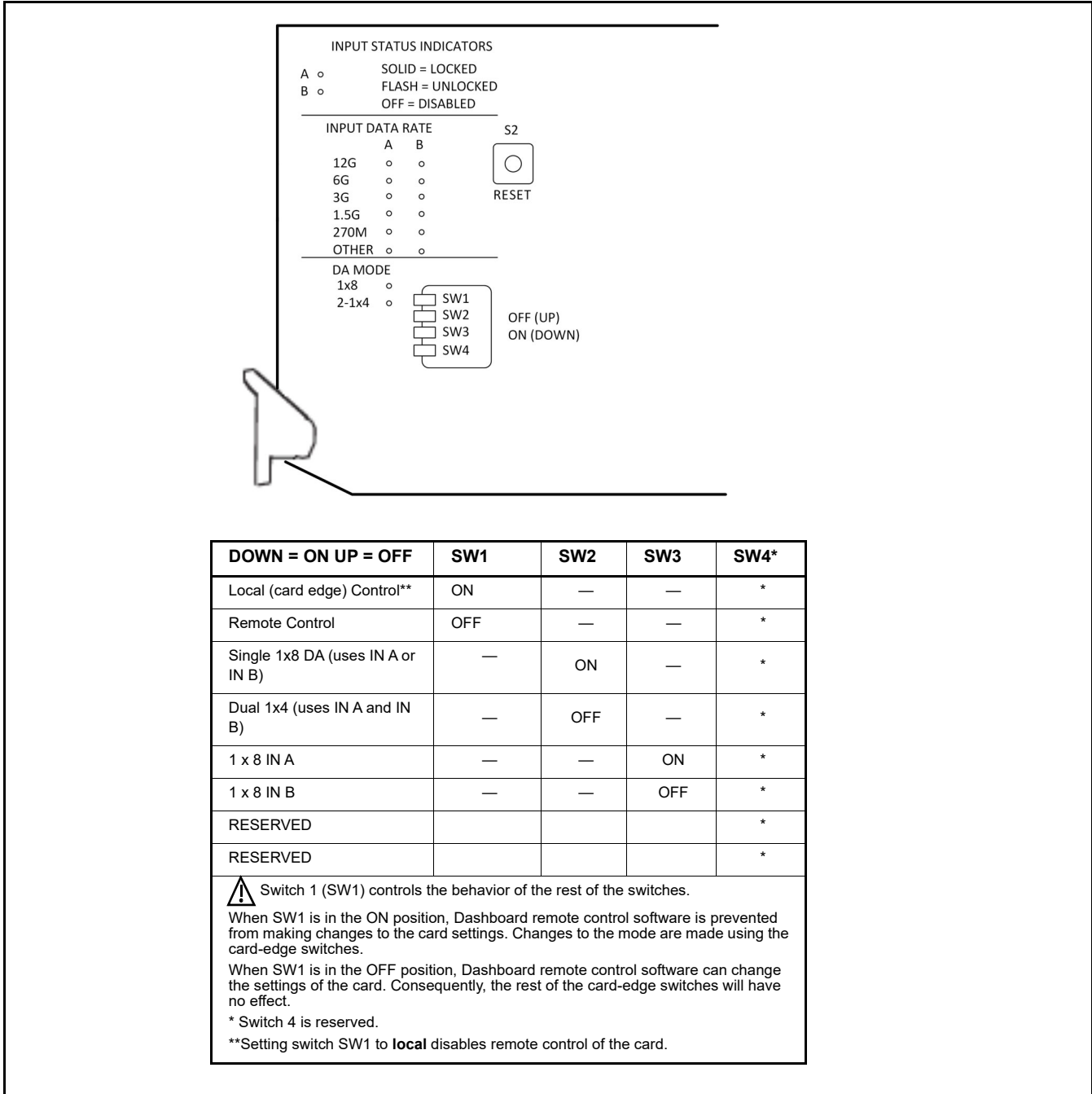

Figure 2-1 Royal 9917-DA-1x8/2x4-12G Card-Edge Indicators and Switches

---

## Card Status Indicators and Switches

The card has the following LEDs to display the status of the SDI inputs:

### Input Status Indicators

These LEDs provide current status information for the card's two inputs.

- Solid light (Locked) indicates there is an SDI signal present.
- Flashing light (Unlocked) indicates there is no SDI signal present.

When the LED is off, the input has been disabled and not in use. To re-enable an input, change the **MODE** setting from the drop-down menu on the Device Tab in DashBoard™ or change the card-edge switch settings. See Device Mode (p. 3-3) for additional information or see “Control Switches” below.

### Input Data Rate

These LEDs indicate which video format the input is locked to. The LEDs are displayed as a solid light. The card provides the following input data rates: 12Gbps, 6Gbps, 3Gbps, 1.5Gbps, 270Mbps, and OTHER, where OTHER indicates a signal (MADI or other signal) is present but not at a rate it can lock to.

### DA Mode

These LEDs indicate which mode is in use (single 1x8 or dual 1x4). A solid light indicates the mode in use. To change the mode, select the desired **MODE** setting from the drop-down menu on the Device Tab in DashBoard™ or change the card-edge switch settings. See Device Mode (p. 3-3) for additional information or refer to “Control Switches” below.

### Control Switches

The card has four switches allowing the user to switch between “Local Control” to set the device mode using the card-edge switches or “Remote Control” to configure all supported card settings through the DashBoard.

To control the device mode using the switches, SW1 must be in the ON position. This enables "Local Control", and disables DashBoard™ controls. Once local control is enabled, you can use a combination of switch settings to change the device mode. SW4 is reserved not used.

- SW1: Local control and defaults to Dual 1x4 Mode
- SW1 and SW2: Local control and Single 1x8 B Mode
- SW1, SW2, and SW3: Local control and Single 1x8 A Mode

To use “Remote Control”, SW1 must be in the OFF position.

### Reset Switch (S2)

Pressing the Reset button reboots the card. After pressing the reset button, the card temporarily disappears from the DashBoard™ but quickly reappears. Pressing the reset button does not affect any settings configured for the card.





---

## Installing the Royal 9917-DA-1x8/2x4-12G Into a Frame Slot

**CAUTION**

This device contains semiconductor devices which are susceptible to serious damage from Electrostatic Discharge (ESD). ESD damage may not be immediately apparent and can affect the long-term reliability of the device.

Avoid handling circuit boards in high static environments such as carpeted areas, and when wearing synthetic fiber clothing. Always use proper ESD handling precautions and equipment when working on circuit boards and related equipment.

**Note:** If installing the Royal 9917-DA-1x8/2x4-12G in a slot with no rear I/O module, a Rear I/O Module is required before cabling can be connected. Refer to Installing a Rear I/O Module (p. 2-6) for rear I/O module installation procedure.

**CAUTION**

If required, make certain Rear I/O Module(s) is installed before installing the Royal 9917-DA-1x8/2x4-12G into the frame slot. Damage to card and/or Rear I/O Module can occur if module installation is attempted with card already installed in slot.

Install the Royal 9917-DA-1x8/2x4-12G into a frame slot as follows:

1. Determine the slot in which the Royal 9917-DA-1x8/2x4-12G is to be installed.
2. Open the frame front access panel.
3. While holding the card by the card edges, align the card such that the plastic ejector tab is on the bottom.
4. Align the card with the top and bottom guides of the slot in which the card is being installed.
5. Gradually slide the card into the slot. When resistance is noticed, gently continue pushing the card until its rear printed circuit edge terminals engage fully into the rear I/O module mating connector.

**CAUTION**

If card resists fully engaging in rear I/O module mating connector, check for alignment and proper insertion in slot tracks. Damage to card and/or rear I/O module may occur if improper card insertion is attempted.

6. Verify that the card is fully engaged in rear I/O module mating connector.
7. Close the frame front access panel.

8. Connect the input and output cables as shown in Royal 9917-DA-1x8/2x4-12G Rear I/O Modules (p. 2-8).
9. Repeat steps 1 through 8 for other Royal 9917-DA-1x8/2x4-12G cards.

**Note:** To remove a card, press down on the ejector tab to unseat the card from the rear I/O module mating connector. Evenly draw the card from its slot.

**Note:** If installing a card in a frame already equipped for, and connected to DashBoard™, no network setup is required for the card. The card will be discovered by DashBoard™ and be ready for use..

## Installing a Rear I/O Module

**Note:** This procedure is applicable **only if a Rear I/O Module is not currently installed** in the slot where the Royal 9917-DA-1x8/2x4-12G is to be installed. If installing the Royal 9917-DA-1x8/2x4-12G in a slot already equipped with a suitable I/O module, omit this procedure.

Install a Rear I/O Module as follows:

1. On the frame, determine the slot in which the Royal 9917-DA-1x8/2x4-12G is to be installed.
2. In the mounting area corresponding to the slot location, install Rear I/O Module as shown in Figure 2-2.

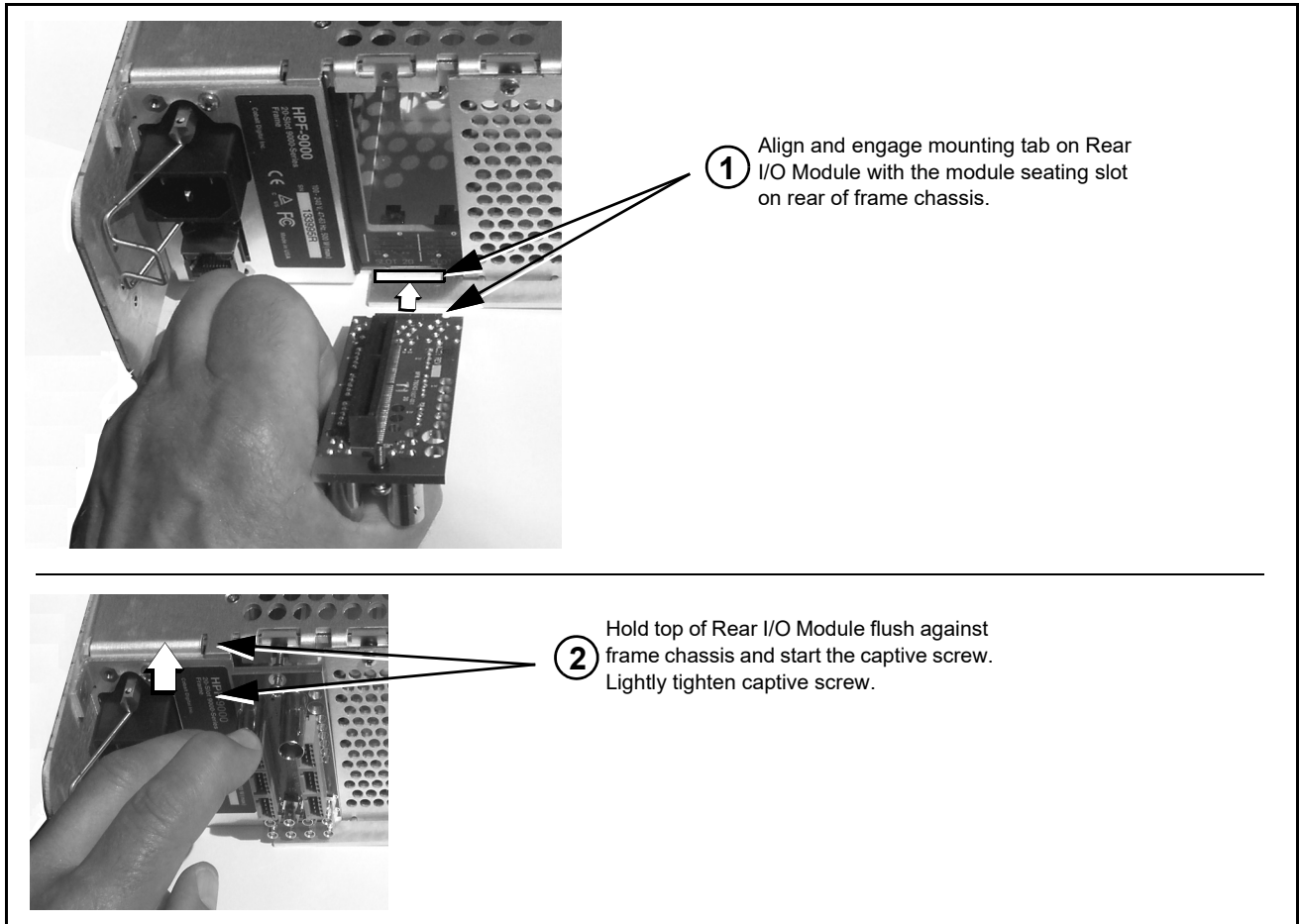
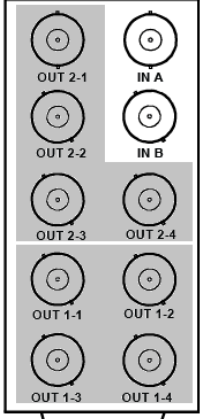
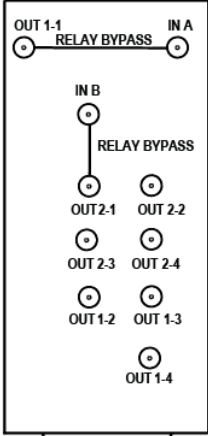

**Figure 2-2 Rear I/O Module Installation**

**Royal 9917-DA-1x8/2x4-12G Rear I/O Modules**

Table 2-1 shows and describes the full assortment of Rear I/O Modules specifically for use with the Royal 9917-DA-1x8/2x4-12G cards.

**Table 2-1 Royal 9917-DA-1x8/2x4-12G Rear I/O Modules**

Royal 9917-DA-1x8/2x4-12G Rear I/O Modules	Description
<p><b>RM20-9917-A</b></p>  <p style="text-align: center;">RM20-DA-1X8/2X4-A</p>	<p>Provides the following connections:</p> <ul style="list-style-type: none"> <li>• Two SDI/ASI video input BNCs (<b>IN A</b> and <b>IN B</b>)</li> <li>• Eight DA outputs: <b>OUT 1-1 thru 1-4</b> <b>OUT 2-1 thru 2-4</b></li> </ul>
<p><b>RM20-9917-B-HDBNC</b></p>  <p style="text-align: center;">RM20-9917-B-HDBNC</p>	<p>Provides the following connections:</p> <ul style="list-style-type: none"> <li>• Two SDI/ASI video inputs (<b>IN A</b> and <b>IN B</b>)</li> <li>• Eight DA outputs: <b>OUT 1-1 thru 1-4</b> <b>OUT 2-1 thru 2-4</b></li> <li>• Two relay bypasses: <b>IN A &gt; OUT 1-4</b> <b>IN B &gt; OUT 2-1</b></li> </ul>

**Table 2-1** Royal 9917-DA-1x8/2x4-12G Rear I/O Modules — *continued*

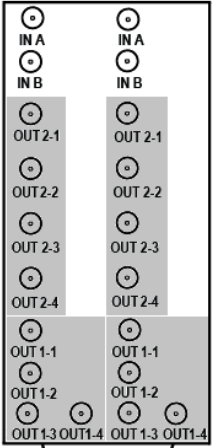
Royal 9917-DA-1x8/2x4-12G Rear I/O Modules	Description
<p><b>RM20-9910-B/S-HDBNC</b></p>  <p style="text-align: center;">RM20-DA-1x8/2x4-B/S-HDBNC</p>	<p>The RM20-DA-1x8/2x4-B/S-HDBNC allows two cards to be installed in adjacent slots and provides the following connections:</p> <ul style="list-style-type: none"> <li>• Four SDI/ASI video inputs (<b>IN A</b> (2) and <b>IN B</b> (2))</li> <li>• Eight DA outputs:             <ul style="list-style-type: none"> <li><b>OUT 1-1 thru 1-4</b> (two sets)</li> <li><b>OUT 2-1 thru 2-4</b> (two sets)</li> </ul> </li> </ul>



# Operating Instructions

## Overview

This chapter contains the following information:

- Accessing the Royal 9917-DA-1x8/2x4-12G Card via Remote Control (p. 3-1)
- Checking Royal 9917-DA-1x8/2x4-12G Card Information and Status (p. 3-1)
- Troubleshooting (p. 3-4)

## Accessing the Royal 9917-DA-1x8/2x4-12G Card via Remote Control

The Royal 9917-DA-1x8/2x4-12G card can be remote monitored via DashBoard™ or Cobalt® Remote Control Panel. Access the Royal 9917-DA-1x8/2x4-12G card using DashBoard™ or Cobalt® Remote Control Panel as described below.

### Accessing the Royal 9917-DA-1x8/2x4-12G Card Using DashBoard™

1. On the computer connected to the frame LAN, open DashBoard™.
2. As shown below, in the left side Basic View Tree locate and expand the Frame containing the Royal 9917-DA-1x8/2x4-12G card to be accessed.

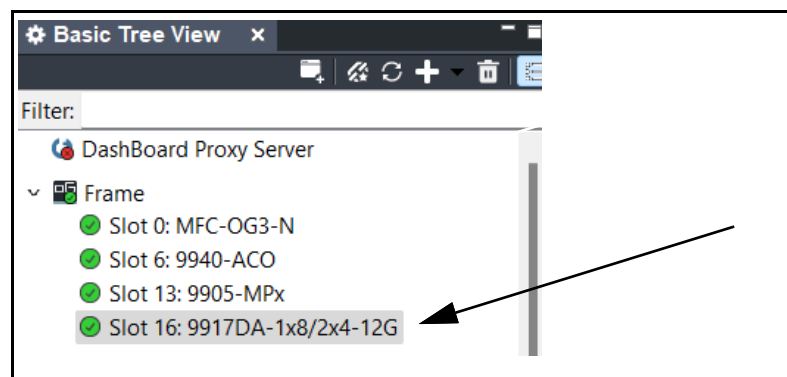

## Checking Royal 9917-DA-1x8/2x4-12G Card Information and Status

The operating status of the Royal 9917-DA-1x8/2x4-12G card can be checked using DashBoard™. shows and describes the Royal 9917-DA-1x8/2x4-12G card information screen using DashBoard™.

The section above the **Status/ Product Info** tabs displays the Card and Connection status.

The **Status** tab displays the:

- Status of how long it takes to save changes. When changes are made, the **Auto save** indicator is yellow and displays a status of pending along with the number of seconds remaining before changes are saved. Once saved, the indicator turns green and displays **Idle**. An Idle status indicates no changes are pending.
- Status of signals being received by the card.
- Status of the output signals.
- Position of the card's switches (on or off)
- Card's operating temperature.
- Internal part number of the Rear I/O module.

The **Product Info** tab shows product identification and firmware version and other details.

Figure 3-1 Royal 9917-DA-1x8/2x4-12G Card Info/Status Utility

## Royal 9917-DA-1x8/2x4-12G Function Menu List and Descriptions

Table 3-1 individually lists and describes each Royal 9917-DA-1x8/2x4-12G function menu and its related list selections, controls, and parameters. Where helpful, examples showing usage of a function are also provided. Table 3-1 is primarily based upon using DashBoard™ to access each function and its corresponding menus and parameters.

**Note:** If card edge control is to be used for card DA mode, refer to Card Control and Status (p. 2-1) in Installation and Setup, Chapter 2.

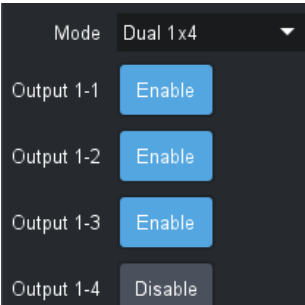
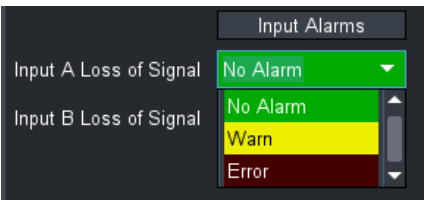

**Table 3-1 9917-DA Function Menu List**

<div style="text-align: center; background-color: #4a7c9c; color: white; padding: 10px; border-radius: 5px;"> <h3>Device Mode</h3> </div>	<p>Provides controls to enable/disable inputs and outputs.</p>
	<p>Use the <b>Mode</b> drop-down menu to enable/disable the inputs as follows:</p> <ul style="list-style-type: none"> <li>• Dual 1x4 - Both inputs are enabled.</li> <li>• Input A 1x8 - Only Input A is enabled.</li> <li>• Input B 1x8 - Only Input B is enabled.</li> </ul> <p>In the single input mode, the outputs that are associated with the disabled input become associated with the other input. This results in 1 SDI input and 8 outputs instead of 2 SDI inputs with 4 outputs each.</p> <p>Use the <b>Enable/Disable</b> buttons to enable and disable the output ports. If you select to disable a port, there will be no SDI signal on that output. This can be used in lieu of using HDBNC terminators.</p>
<div style="text-align: center; background-color: #4a7c9c; color: white; padding: 10px; border-radius: 5px;"> <h3>Alarms</h3> </div>	<p>For each input, provides independent controls for setting up input Loss of Signal alarm propagation to Card state and DashBoard Tree View alarm indicators/ messages.</p>
<ul style="list-style-type: none"> <li>• <b>Warn</b> propagates a <b>Yellow</b> alarm to both the Card state and DashBoard Tree View indicator.</li> <li>• <b>Warn</b> propagates a <b>Yellow</b> alarm to both the Card state and DashBoard Tree View indicator.</li> </ul>  <ul style="list-style-type: none"> <li>• <b>Error</b> propagates a <b>Red</b> alarm to both the Card state and DashBoard Tree View indicator.</li> </ul> <p><b>Note:</b> For any unused inputs, set control for <b>No Alarm</b> to avoid nuisance false alarms.</p>	<div style="display: flex; flex-direction: column; gap: 10px;"> <div style="border: 1px solid #4a7c9c; padding: 5px; background-color: #333; color: white;"> <p>Slot 16: 9917DA-1x8/2x4-12G</p> <p>Card state: <span style="color: green;">●</span> OK</p> <p>Connection: <span style="color: green;">●</span> ONLINE</p> <p>▼ Frame</p> <ul style="list-style-type: none"> <li><span style="color: green;">●</span> Slot 0: MFC-OG3-N</li> <li><span style="color: green;">●</span> Slot 6: 9940-ACO</li> <li><span style="color: green;">●</span> Slot 16: 9917DA-1x8/2x4-12G</li> </ul> </div> <div style="border: 1px solid #4a7c9c; padding: 5px; background-color: #333; color: white;"> <p>Slot 16: 9917DA-1x8/2x4-12G</p> <p>Card state: <span style="color: yellow;">●</span> Loss of Signal In A</p> <p>Connection: <span style="color: green;">●</span> ONLINE</p> <p>▼ Frame</p> <ul style="list-style-type: none"> <li><span style="color: green;">●</span> Slot 0: MFC-OG3-N</li> <li><span style="color: green;">●</span> Slot 6: 9940-ACO</li> <li><span style="color: yellow;">●</span> Slot 16: 9917DA-1x8/2x4-12G</li> </ul> </div> <div style="border: 1px solid #4a7c9c; padding: 5px; background-color: #333; color: white;"> <p>Slot 16: 9917DA-1x8/2x4-12G</p> <p>Card state: <span style="color: red;">●</span> Loss of Signal In A</p> <p>Connection: <span style="color: green;">●</span> ONLINE</p> <p>▼ Frame</p> <ul style="list-style-type: none"> <li><span style="color: green;">●</span> Slot 0: MFC-OG3-N</li> <li><span style="color: green;">●</span> Slot 6: 9940-ACO</li> <li><span style="color: red;">●</span> Slot 16: 9917DA-1x8/2x4-12G</li> </ul> </div> </div>

## Troubleshooting

This section provides general troubleshooting information and specific symptom/corrective action for the card and its remote control interface. The card requires no periodic maintenance in its normal operation; if any error indication (as described in this section) occurs, use this section to correct the condition.

### DashBoard™ Status/Error Indicators and Displays

Figure 3-2 shows and describes the DashBoard™ status indicators and displays. These indicator icons and displays show status and error conditions relating to the Royal 9917-DA-1x8/2x4-12G card itself and remote (network) communications.

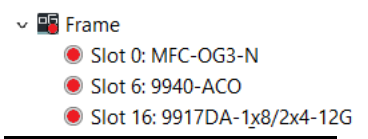
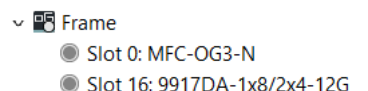
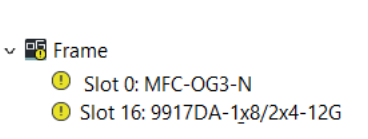
Indicator Icon or Display	Error Description
 <p>Slot 16: 9917DA-1x8/2x4-12G Card state: <span style="color: red;">●</span> No connection to device. Connection: <span style="color: gray;">●</span> NO CONNECTION TO FRAME</p>	<p>The Red indicator icon in the Card Access/Navigation Tree pane shows cards with general Error conditions including the 9917-DA-1x8/2x4-12G card in Slot 16 in this example.</p> <p>Specific errors are displayed in the Card Info pane by clicking on a card. In this example clicking on "Slot 16: 9917DA-1x8/2x4-12G" displays "No connection to device" in the <b>Card state</b> field and "NO CONNECTION TO FRAME" in the <b>Connection</b> field indicating the Royal 9917-DA-1x8/2x4-12G card is not connecting to the Frame.</p>
 <p>Slot 16: 9917DA-1x8/2x4-12G</p>	<p>The Gray indicator icon in the Card Access/Navigation Tree pane shows cards that are not being seen by DashBoard™ due to a lack of connection to the Frame including the 9917-DA-1x8/2x4-12G card in Slot 16 in this example.</p>
 <p>Slot 16: 9917DA-1x8/2x4-12G Card state: <span style="color: yellow;">●</span> Loss of Signal In A Connection: <span style="color: green;">●</span> ONLINE</p>	<p>The Yellow indicator icon in the Card Access/Navigation Tree pane shows cards with general Warning conditions including the 9917-DA-1x8/2x4-12G card in Slot 16 in this example.</p> <p>Specific errors are displayed in the Card Info pane by clicking on a card. In this example clicking on "Slot 16: 9917DA-1x8/2x4-12G" displays "Loss of Signal In A" in the <b>Card state</b> field and "ONLINE" in the <b>Connection</b> field indicating the Royal 9917-DA-1x8/2x4-12G is online but a loss of Signal for Input A has occurred.</p>

**Figure 3-2 DashBoard™ Status Indicator Icons and Displays**

## Basic Troubleshooting Checks

Failures of a general nature (affecting many cards and/or functions simultaneously), or gross inoperability errors are best addressed first by performing basic checks before proceeding further. Table 3-2 provides basic system checks that typically locate the source of most general problems. If required and applicable, perform further troubleshooting in accordance with the other troubleshooting tables in this section.

**Table 3-2 Basic Troubleshooting Checks**

Item	Checks
<b>Check Cable connection secureness and connecting points</b>	Make certain all cable connections are fully secure (including coaxial cable attachment to cable ferrules on BNC connectors). Also, make certain all connecting points are as intended. Make certain the selected connecting points correlate to the intended card inputs and/or outputs. Cabling mistakes are especially easy to make when working with large I/O modules.
<b>Card seating within slots</b>	Make certain all cards are properly seated within its frame slot. (It is best to assure proper seating by ejecting the card and reseating it again.)
<b>Check status indicators</b>	The DashBoard™ and the Royal 9917-DA-1x8/2x4-12G card provide indicators to signify errors and warnings. If a status indicator signifies an error or warning, proceed to the following table in this section for further action.
<b>Check card-edge switch settings</b>	Refer to Chapter 2, Setup and Installation. Make certain switches are set for intended control mode (local or remote). If set for local, remote control is locked out.
<b>Troubleshoot by substitution</b>	All cards within the frame can be hot-swapped, replacing a suspect card or module with a known-good item.

## Royal 9917-DA-1x8/2x4-12G Processing Error Troubleshooting

Table 3-3 provides card processing troubleshooting information. If the card exhibits any of the symptoms listed in Table 3-3, follow the troubleshooting instructions provided.

In the majority of cases, most errors are caused by simple errors where the card is not appropriately set for the signal(s) to be received by the card.

**Table 3-3 Troubleshooting Processing Errors by Symptom**

Symptom	Error/Condition	Corrective Action
DashBoard™ displays a red or yellow indicator in the Card Info pane.	May indicate a signal loss for an input or the card may not be connected and appear offline. Refer to the <b>Card state</b> and <b>Connection</b> fields for the specific issue.	Make certain intended video sources are connected to appropriate card video inputs. Make certain coaxial cable connections between Rear I/O Module for the card and signal source are OK.
Card will not save presets.	Memory needs reset (rare condition corrected in latest firmware releases)	<ol style="list-style-type: none"> <li>1. Power-down card (pull from frame enough to access DIP switch).</li> <li>2. Set SW4 to ON (down) position.</li> <li>3. Push card back into slot to power-up card again.</li> <li>4. Immediately (within 3 seconds) set SW4 to OFF (up) position. Card will now save presets.</li> </ol>

## Troubleshooting Network/Remote Control Errors

Refer to Cobalt® reference guide “Remote Control User Guide” (PN 9000RCS-RM) for network/remote control troubleshooting information.

## In Case of Problems

Should any problem arise with this product that was not solved by the information in this section, please contact the Cobalt Digital Inc. Technical Support Department.

If required, a Return Material Authorization number (RMA) will be issued to you, as well as specific shipping instructions. If required, a temporary replacement item will be made available at a nominal charge. Any shipping costs incurred are the customer’s responsibility. All products shipped to you from Cobalt Digital Inc. will be shipped collect.

The Cobalt Digital Inc. Technical Support Department will continue to provide advice on any product manufactured by Cobalt Digital Inc., beyond the warranty period without charge, for the life of the product.

See Contact Cobalt Digital Inc. (p. 1-8) in Chapter 1, “Introduction“ for contact information.





**Cobalt Digital Inc.**

2506 Galen Drive  
Champaign, IL 61821  
Voice 217.344.1243 • Fax 217.344.1245  
[www.cobaltdigital.com](http://www.cobaltdigital.com)