

UltraBlue IP-MV ● Software Based Multiviewer

The COBALT® **UltraBlue IP-MV** is a multiviewer software solution with the following features:

- Support for receiving audio/video content over IP over a variety of protocols and formats
- Support for multiple screens (heads) with arbitrary sizes and orientations
- Flexible support for graphical overlays, as well as UMDs and IDs
- Support for the most common types of ancillary data, including various types of Closed-Captioning and Timecode
- Flexible audio support, including audio bars and audio output monitoring
- Support for tally
- Configurable alarms
- HDMI and compressed outputs

The general architecture is depicted in the block diagram below

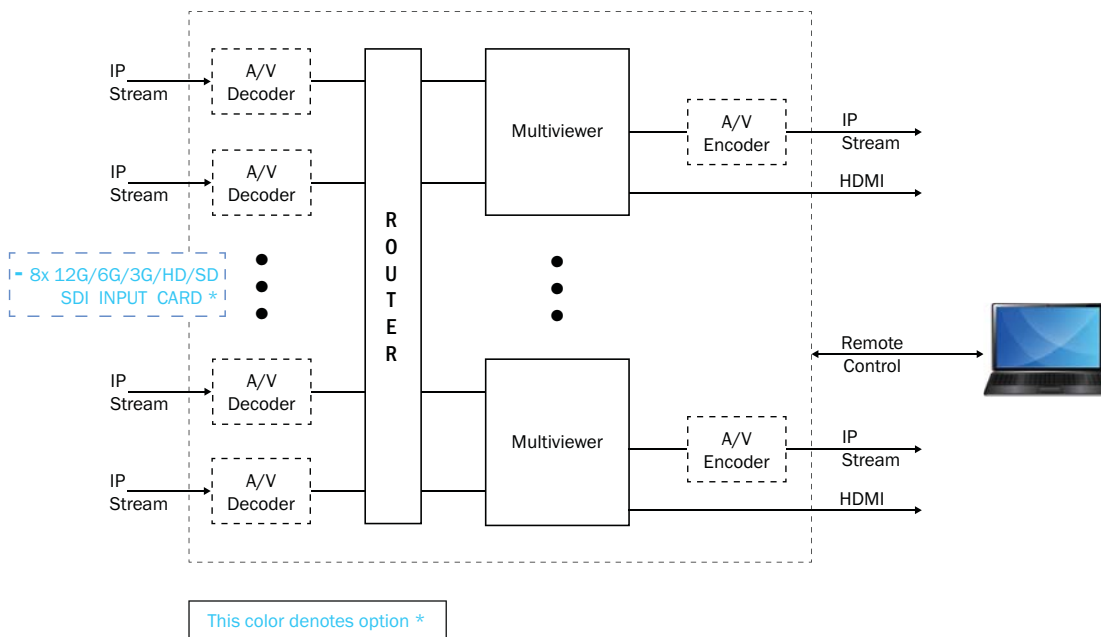

UltraBlue IP-MV will be provided as an x86-64 container image, which can be run in the following environments:

- A customer-supplied x86 64-bit PC
- A cloud instance running on equivalent hardware

In both cases, **UltraBlue IP-MV** will be able to use GPU acceleration if available. The number of inputs, streams, and heads will be a function of the available CPU/GPU.

There is a separate user interface to configure the **UltraBlue IP-MV**. This user interface can be accessed on the local device itself, or remotely over a network. It supports multiple user logins, and per-user access privileges.

For customer-supplied PCs, **UltraBlue IP-MV** will be able to drive multiple HDMI displays in any orientation (landscape or portrait, selectable per-display)

For cloud instances, **UltraBlue IP-MV** will create a WebRTC low-latency stream that can be received by any modern web device.

UltraBlue IP-MV ● Software Based Multiviewer

FEATURES

Input Protocol Support

At first release, **UltraBlue IP-MV** will support the following network protocols:

- TS over UDP
- TS over RTP, compliant with SMPTE ST 2022-2
- TS over RTP with FEC, compliant with SMPTE ST 2022-1
- RIST Simple Profile, compliant with VSF TR-06-1
- RIST Main Profile Baseline Level, compliant with VSF TR-06-2
- SRT caller/listener/rendezvous1
- SMPTE ST 2110-20 (uncompressed video) up to 3840x2160p60
- RTMP Client (allowing IPMV to “pull” content from servers)

The following protocols are planned for later releases:

- RTSP Client
- RTMP Server (allowing RTMP Clients to connect to IPMV)
- HLS client (allowing IPMV to “pull” an HLS feed)
- DASH client (allowing IPMV to “pull” a DASH feed)
- WebRTC client (allowing IPMV to “pull” a WebRTC feed)

Video Input Support

At first release, **UltraBlue IP-MV** will support the following formats, including support for 8-bit/10-bit and 4:2:0/4:2:2:

- H.262 (MPEG-2), up to 1920x1080p60
- H.264 (AVC), up to 3840x2160p60
- H.265 (HEVC), up to 3840x2160p60
- SMPTE ST 2110-20 (uncompressed video) up to 3840x2160p60

The following formats are planned for later releases:

- SMPTE ST 2110-22 (JPEG-XS) up to 3840x2160p60
- JPEG-2K up to 3840x2160p60
- NDI up to 3840x2160p60
- SD-SDI, HD-SDI, 3G-SDI, 12G-SDI

Support for ST 2110-20 will require a suitable CPU platform with Cobalt-specified 25Gb and 100Gb Ethernet interfaces, depending on video resolution.

Support for baseband SDI will require a suitable CPU platform with Cobalt-specified capture cards. *NOTE: See OPTIONS BELOW

Audio Input Support

At first release, **UltraBlue IP-MV** will support the following audio formats:

- MPEG-1 Layer I, II and III (stereo)
- AAC-LC (stereo and 5.1)
- HE-AAC v1 (stereo and 5.1)
- HE-AAC v2 (stereo)
- Dolby AC-3/EAC-3 (stereo and 5.1)
- SMPTE ST 2110-30 uncompressed audio
- Support for SMPTE ST 2110-40 Ancillary Data

The following formats are planned for later releases:

- Dolby AC-4 (stereo and 5.1)
- Dolby E (full support up to 8 channels)
- SMPTE ST 302-M LPCM

Multiviewer Functionality

At first release, **UltraBlue IP-MV** will have the following functionality:

- Support for multiple users with different levels of access.
- Support for saving and recalling presets.
- Arbitrary PIP sizing, positioning, and rotation.
- Arbitrary image and text overlay.
- Support for audio bars.
- Support for on-screen EIA-608/708 Closed-Captioning encapsulated in the video elementary stream using A/53.
- Basic stream presence/absence alarms.
- Tally support.

The following features are planned for later releases:

- Other ancillary data support (including SMPTE ST 2038)
- Support for OP-47 Closed Captions.
- More advanced monitoring functions (frozen video, no audio, TR 101 290 monitoring)

Output Support

At first release, **UltraBlue IP-MV** will have the following output support:

- Multiple HDMI heads, with arbitrary routing.
- Arbitrary audio routing to HDMI outputs.
- Display Port support.

The following features are planned for later releases:

- WebRTC low-latency output (for streaming) with arbitrary audio routing.
- HLS server output with arbitrary audio routing.

OPTIONS

* **UltraBlue IP-MV Option - 8x12GSDI** adds 8 HD-BNC SDI inputs per PCIe card. Supports 12G/6G/3G/HD/SD SDI and ASI

1 SRT rendezvous mode is known to have severe technical limitations. Rendezvous mode is provided “as-is” with no performance warranties.